

# LumiCzar

**Model No. - LZR-XSM02**

LED Exit Signage Light – Self Contained - Basic

## General

The **LZR-XSM02** is a simple yet packed with technology to deliver high lumens with low power and exceptionally long battery backup above 90 minutes.



## Features

- Long life
- Superior quality
- Low power consumption
- Battery backup above 1.5Hours
- Battery life upto 5 years or 500+ lifecycle
- LED driver extends the lamp life upto 60,000 hours
- Dual color LED used to identify the AC supply / Battery operating status
- Easy to replace/change the signage board.
- Terminate switch helps to avoid the battery discharge until the light used in the field
- Universal Mounting

## Specifications

### Emergency Light Wireless – Specification

<b>Input voltage</b>	200VAC to 265VAC, 47Hz to 63Hz, 1-ph
<b>Housing</b>	Aluminium with white colour.
<b>Light source</b>	LED (6500K), 2Watts
<b>Viewing Distance</b>	≥22 meters
<b>Battery Backup</b>	≥90 Minutes
<b>Battery type</b>	Ni-MH Rechargeable Battery
<b>Battery Cycle</b>	≥500 Cycle
<b>Weight</b>	1100 grams approximately
<b>Dimension</b>	314mm (L) , 35mm(D), 242 mm (H)
<b>Application</b>	Indoor - commercial and industrial use
<b>Mounting</b>	Hanging, Wall and Ceiling option: Recessed Mount
<b>IP Rating</b>	IP20
<b>Manufacturing</b>	India
<b>Operating Temp</b>	0°C to 50°C
<b>Designed</b>	As per EMI/EMC compliance. Safety tested EN 61547:2009, EN 55015:2013+A1:2015, EN 61000-3-2:2014, EN 61000-3-3:2013, IEC/EN 60598-2-22(3rd Edition):1997+A1:2002+A2:2008, IEC/EN60598-1(7th Edition)

## Legend Panels



Sl.No	Legend Panels	Code
1	Man running with right arrow	MR
2	Man running with Left arrow	ML
3	Man running with down arrow	MD
4	Man running with up arrow	MU
5	EXIT sign	EXIT

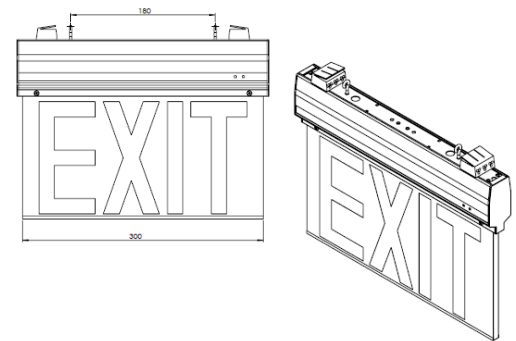

### India

RAVEL ELECTRONICS PVT LTD.,  
150A, Electronics Industrial Estate,  
Perungudi, Chennai – 96, India.  
E-mail: [marketing@ravelfire.com](mailto:marketing@ravelfire.com); Web: [www.ravelfire.com](http://www.ravelfire.com)

### United Kingdom

RAVEL ELECTRONICS LTD.,  
Unit 11, Chancel Industrial Estate, Newhall street,  
Willenhall WV13 1NX, West Midlands, United Kingdom.  
E-mail: [info@ravelfire.co.uk](mailto:info@ravelfire.co.uk); Web: [www.ravelfire.co.uk](http://www.ravelfire.co.uk)

### USA

RAVEL AMERICAS INC.,  
2855 NW 112<sup>th</sup> Ave ST#2 Miami,  
Doral, Florida 33172, USA.